

# PR



## 9 2 0 3

Ventil- / alarmdriver

Nr. 9203V102-DK

Produktversion: 9203-002



SIGNALS THE BEST

- DK ▶** PR electronics A/S tilbyder et bredt program af analoge og digitale signalbehandlingsmoduler til industriel automation. Programmet består af Isolatorer, Displays, Ex-barrierer, Temperaturtransmittere, Universaltransmittere mfl. Vi har modulerne, du kan stole på i selv barske miljøer med elektrisk støj, vibrationer og temperaturudsving, og alle produkter opfylder de strengeste internationale standarder. Vores motto »Signals the Best« er indbegrebet af denne filosofi – og din garanti for kvalitet.
- UK ▶** PR electronics A/S offers a wide range of analogue and digital signal conditioning modules for industrial automation. The product range includes Isolators, Displays, Ex Interfaces, Temperature Transmitters, and Universal Modules. You can trust our products in the most extreme environments with electrical noise, vibrations and temperature fluctuations, and all products comply with the most exacting international standards. »Signals the Best« is the epitome of our philosophy – and your guarantee for quality.
- FR ▶** PR electronics A/S offre une large gamme de produits pour le traitement des signaux analogiques et numériques dans tous les domaines industriels. La gamme de produits s'étend des transmetteurs de température aux afficheurs, des isolateurs aux interfaces SI, jusqu'aux modules universels. Vous pouvez compter sur nos produits même dans les conditions d'utilisation sévères, p.ex. bruit électrique, vibrations et fluctuations de température. Tous nos produits sont conformes aux normes internationales les plus strictes. Notre devise »SIGNALS the BEST« c'est notre ligne de conduite - et pour vous l'assurance de la meilleure qualité.
- DE ▶** PR electronics A/S verfügt über ein breites Produktprogramm an analogen und digitalen Signalverarbeitungsmodulen für die industrielle Automatisierung. Dieses Programm umfasst Displays, Temperaturtransmitter, Ex- und galvanische Signaltrenner, und Universalgeräte. Sie können unsere Geräte auch unter extremen Einsatzbedingungen wie elektrisches Rauschen, Erschütterungen und Temperaturschwingungen vertrauen, und alle Produkte von PR electronics werden in Übereinstimmung mit den strengsten internationalen Normen produziert. »Signals the Best« ist Ihre Garantie für Qualität!

# VENTIL- / ALARMDRIVER

9203

## INDHOLD

Advarsel.....	2
Signaturforklaring .....	2
Sikkerhedsregler.....	2
Afmontering af system 9000 .....	4
EF-Overensstemmelseserklæring .....	5
Avancerede features.....	6
Anvendelse .....	6
Teknisk karakteristik .....	6
Applikationer .....	7
PR 4501 Display- / programmeringsfront .....	8
Bestillingsskema: 9203B.....	9
Elektriske specifikationer.....	9
SIL2 Certified & Fully Assessed acc. to IEC 61508.....	12
Hardware- / softwarefejl.....	13
Tilslutninger .....	14
Blokdiagram .....	15
Visning af signalfejl uden displayfront.....	16
Programmering / betjening af trykknapper .....	16
Rutediagram .....	18
Rutediagram, Avancerede indstillinger (ADV.SET) .....	19
Rullende hjælpetekster i displaylinie 3.....	20
Appendix .....	21
IECEX Installation Drawing .....	22
ATEX Installationstegning .....	25
FM Installation Drawing.....	28
Safety Manual.....	30



## ADVARSEL

Følgende operationer bør kun udføres på modulet i spændingsløs tilstand og under ESD-sikre forhold:

- Installation, ledningsmontage og -demontage.
- Fejlfinding på modulet.

**Reparation af modulet og udskiftning af sikringer må kun foretages af PR electronics A/S.**



## ADVARSEL

Modulets frontplade må ikke åbnes, da dette vil medføre skade på stikforbindelsen til display- / programmeringsfronten PR 4501. Modulet indeholder ingen DIP-switches eller jumpere.

## SIGNATURFORKLARING



Trekant med udråbstegn: Læs manualen før installation og idriftsættelse af modulet for at undgå hændelser, der kan føre til skade på personer eller materiel.



CE-mærket er det synlige tegn på modulets overensstemmelse med EU-direktivernes krav.



Dobbelt isolation er symbolet for, at modulet overholder ekstra krav til isolation.



Ex - Modulet er godkendt efter ATEX-direktivet til brug i forbindelse med installationer i eksplosionsfarlige områder. Se installation drawings i appendiks.

## SIKKERHEDSREGLER

### DEFINITIONER

**Farlige spændinger** er defineret som områderne: 75...1500 Volt DC og 50...1000 Volt AC.

**Teknikere** er kvalificerede personer, som er uddannet eller oplært til at kunne udføre installation, betjening eller evt. fejlfinding både teknisk og sikkerhedsmæssigt forsvarligt.

**Operatører** er personer, som under normal drift med produktet skal indstille og betjene produktets trykknapper eller potentiometre, og som er gjort bekendt med indholdet af denne manual.

## **MODTAGELSE OG UDPAKNING**

Udpak modulet uden at beskadige det. Kontrollér ved modtagelsen, at modultypen svarer til den bestilte. Indpakningen bør følge modulet, indtil dette er monteret på blivende plads.

## **MILJØFORHOLD**

Undgå direkte sollys, kraftigt støv eller varme, mekaniske rystelser og stød, og udsæt ikke modulet for regn eller kraftig fugt. Om nødvendigt skal opvarmning, ud over de opgivne grænser for omgivelsestemperatur, forhindres ved hjælp af ventilation.

Modulet skal installeres i forureningsgrad 2 eller bedre.

Modulet er designet til at være sikkert mindst op til en højde af 2000 m.

## **INSTALLATION**

Modulet må kun tilsluttes af teknikere, som er bekendte med de tekniske udtryk, advarsler og instruktioner i manualen, og som vil følge disse.

Hvis der er tvivl om modulets rette håndtering, skal der rettes henvendelse til den lokale forhandler eller alternativt direkte til:

**PR electronics A/S**  
**[www.prelectronics.dk](http://www.prelectronics.dk)**

Ved tilslutning af flerkorede ledninger med farlig spænding skal ledningsenderne forsynes med ledningstykker.

Beskrivelse af indgang / udgang og forsyningsforbindelser findes på blokdiagrammet og sideskiltet.

Modulet er forsynet med skrueterminaler og skal forsynes fra en dobbeltisoleret/forstærket isoleret spændingsforsyning. En afbryder placeres let tilgængeligt og tæt ved modulet. Afbryderen skal mærkes således, at der ikke er tvivl om, at den afbryder spændingen til modulet.

Ved installation på Power Rail 9400 bliver forsyningsspændingen leveret af Power Control Unit type 9410.

Produktionsår fremgår af de to første cifre i serienummeret.

## **KALIBRERING OG JUSTERING**

Under kalibrering og justering skal måling og tilslutning af eksterne spændinger udføres i henhold til denne manual, og teknikeren skal benytte sikkerhedsmæssigt korrekte værktøjer og instrumenter.

## **BETJENING UNDER NORMAL DRIFT**

Operatører må kun indstille eller betjene modulerne, når disse er fast installeret på forsvarlig måde i tavler el. lignende, så betjeningen ikke medfører fare for liv eller materiel. Dvs., at der ikke er berøringsfare, og at modulet er placeret, så det er let at betjene.

## **RENGØRING**

Modulet må, i spændingsløs tilstand, rengøres med en klud let fugtet med destilleret vand.

## **ANSVAR**

I det omfang instruktionerne i denne manual ikke er nøje overholdt, vil kunden ikke kunne rette noget krav, som ellers måtte eksistere i henhold til den indgåede salgsaftale, mod PR electronics A/S.

## **AFMONTERING AF SYSTEM 9000**



### **Billede 1:**

Modulet frigøres fra power railen ved at løfte i den nederste lås.

# EF-OVERENSSTEMMELSESERKLÆRING

Som producent erklærer

**PR electronics A/S**  
**Lerbakken 10**  
**DK-8410 Rønde**

hermed at følgende produkt:

**Type: 9203**  
**Navn: Ventil- / alarmdriver**

er i overensstemmelse med følgende direktiver og standarder:

EMC-direktivet 2004/108/EF og senere tilføjelser

**EN 61326-1 : 2006**

For specifikation af det acceptable EMC-niveau henvises til modulets elektriske specifikationer.

Lavspændingsdirektivet 2006/95/EF og senere tilføjelser

**EN 61010-1 : 2001**

ATEX-direktivet 94/9/EF og senere tilføjelser

**EN 60079-0:2009, EN 60079-11:2007, EN 60079-15:2005,**  
**EN 60079-26:2007, EN 61241-11:2006.**  
**ATEX-certifikat: KEMA 07ATEX0147 X**

Bemyndiget organ:

**DEKRA Certification B.V. (0344)**  
**Utrechtseweg 310, 6812 AR Arnhem**  
**P.O. Box 5185, 6802 ED Arnhem**  
**The Netherlands**

Rønde, 10. februar 2012



---

Kim Rasmussen  
Producentens underskrift

# VENTIL- / ALARMDRIVER

## 9203

- *Universel Ex-driver for ventiler, akustiske alarmer og lysdioder*
- *Udvidet autodiagnosticering*
- *1 eller 2 kanaler*
- *Kan forsynes separat eller installeres på power rail, PR type 9400*
- *SIL 2-certificeret via Full Assessment*

### Avancerede features

- Universel Ex-driver til styring af ventiler mm. med forskellige Ex-data vha. 3 indbyggede Ex-barrierer.
- To hardwareversioner giver mulighed for valg af Low (35 mA) eller High (60 mA) strømudgang.
- Opsætning og monitorering via aftagelig displayfront (PR 4501).
- Valg af direkte eller indirekte funktion for hver kanal via PR 4501 og mulighed for at reducere udgangsstrømmen til Ex-området efter behov.
- Mulighed for monitorering af udgangsstrømmen til Ex-område via PR 4501.
- Mulighed for redundant forsyning via power rail og/eller separat forsyning.

### Anvendelse

- 9203 kan monteres i sikkert område samt i zone 2 / division 2 og sende signaler til zone 0, 1, 2, 20, 21, 22 og M1 / Class I/II/III, Div. 1, Gr. A-G.
- Ex-driver til styring af ON / OFF ventiler, akustiske alarmer og lysdioder placeret i eksplosionsfarligt område.
- 9203 styres af et NPN-/PNP-signal eller et kontaktsignal.
- Overvågning af interne fejlsituationer via det individuelle statusrelæ og / eller kollektivt elektronisk signal via power rail.
- 9203 er konstrueret, udviklet og certificeret til brug i SIL 2 installationer iht. kravene i IEC 61508.

### Teknisk karakteristik

- 1 grøn og 2 gule/røde LEDs i front indikerer normal drift og funktionsfejl.
- 2,6 kVAC galvanisk isolation mellem indgang, udgang og forsyning.



# APPLIKATIONER

## Udgangssignaler:

Kanal 1

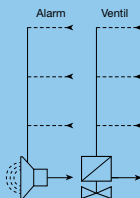

Kanal 2

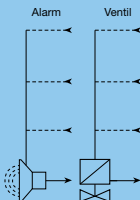

**Zone 0, 1, 2,  
20, 21, 22, M1 &  
Cl. I/II/III, div. 1  
gr. A-G**

## Indgangssignaler:

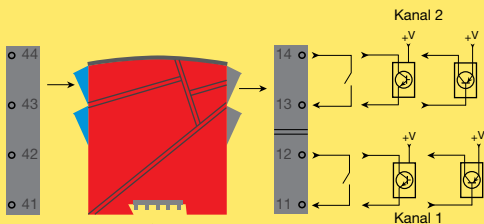

Power rail



## Forsyningsspændinger:

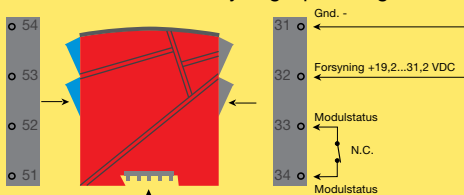

**Zone 2 / Cl. 1, div. 2, gr. A-D eller sikkert område**

# PR 4501 DISPLAY- / PROGRAMMERINGSFRONT



## Funktionalitet

Den enkle menustruktur og de forklarende hjælpetekster leder dig automatisk gennem opsætningen og gør produktet meget enkelt at anvende. Se beskrivelse af funktioner og opsætningsmuligheder under afsnittet "Programmering / betjening af trykknapper".

## Anvendelse

- Kommunikationsinterface til ændring af driftsparametre i 9203.
- Som fastmonteret display til visualisering af procesdata og status.

## Teknisk karakteristik:

- Fire liniers LCD-display, linie 1 (5,57 mm høj) viser hver kanals status (OK eller fejl). Linie 2 (3,33 mm høj) viser kanal 1's udgang (ON / OFF), linie 3 (3,33 mm høj) viser kanal 2's udgang (ON / OFF) og linie 4 viser, om modulet er SIL-låst. Statisk prik = SIL-låst og blinkende prik = ikke SIL-låst. Linie 4 viser også, om udgangen er aktiv.
- For at undgå uautoriseret brug kan konfigurationen beskyttes med et password.

## Montage / installation

- Klikkes på fronten af 9203.

## Bestillingsskema : 9203B



Type	Ex-barriere [Ex ia]	Kanaler
9203B	Low current . . . : 1	Enkelt . . . : A Dobbelt. . . : B
	High current . . . : 2	Enkelt . . . : A

**4501 = Display- / programmeringsfront**

**9400 = Power rail**

### Elektriske specifikationer

Specifikationsområde..... -20...+60°C

Lagringstemperatur..... -20...+85°C

### Fælles specifikationer:

Forsyningsspænding..... 19,2...31,2 VDC

Max. forbrug..... ≤ 3,5 W (2 kanaler)

Sikring ..... 1,25 A T / 250 VAC

Isolationsspændinger, test / drift

Indgange / udgange / forsyning..... 2,6 kVAC / 250 VAC forstærket

Udgang 1 til udgang 2 ..... 1,5 kVAC / 150 VAC forstærket

Statusrelæ til forsyning ..... 1,5 kVAC / 150 VAC forstærket

Kommunikationsinterface..... Programmeringsfront 4501

Kalibreringstemperatur..... 20...28°C

EMC-immunitetspåvirkning.....	< ±0,5% af span
-------------------------------	-----------------

Udvidet EMC-immunitet:

NAMUR NE 21, A kriterium, gniststøj.....	< ±1% af span
--	---------------

Ledningskvadrat (min. / max.)..... 0,13...2,08 mm<sup>2</sup> / AWG 26...14  
flerkoret ledning

Klemskruetilspændingsmoment..... 0,5 Nm

Relativ luftfugtighed ..... < 95% RH (ikke kond.)

Mål, uden displayfront (HxBxD) ..... 109 x 23,5 x 104 mm

Mål, med displayfront (HxBxD) ..... 109 x 23,5 x 116 mm

Kapslingsklasse..... IP20

Vægt ..... 170 g / 185 g med 4501

**NPN og mekanisk kontakt:**

Trig-niveau LOW.....	≤ 2,0 VDC
Trig-niveau HIGH.....	≥ 4,0 VDC
Max. ekstern spænding .....	28 VDC
Indgangsimpedans.....	3,50 kΩ

**PNP:**

Trig-niveau LOW.....	≤ 8,0 VDC
Trig-niveau HIGH.....	≥ 10,0 VDC
Max. ekstern spænding .....	28 VDC
Indgangsimpedans.....	3,50 kΩ

**Speciel PNP trig-indgang:**

Hvis indgangssignalet kommer fra et apparat, hvor udgangen er forbundet som en åben kollektor med pull-up modstand, skal en diode forbindes i serie med indgangssignalet. Se tilslutningstegninger på side 14 for detaljer.

**Udgange:**

Udgangsripple..... < 40 mV RMS

**Ex-data:**

	9203B1A / 9203B1B								
	Klemme 41-42 / 51-52			Klemme 41-43 / 51-53			Klemme 41-44 / 51-54		
Uo	28 V			28 V			28 V		
Io	93 mA			100 mA			110 mA		
Po	0,65 W			0,70 W			0,77 W		
Vudgang ubelastet	Min. 24 V			Min. 24 V			Min. 24 V		
Vudgang belastet	Min. 12,5 V			Min. 13,5 V			Min. 14,5 V		
Iudg. max	35 mA			35 mA			35 mA		
	IIC	IIB	IIA	IIC	IIB	IIA	IIC	IIB	IIA
Co	80 nF	640 nF	2,1 μF	80 nF	640 nF	2,1 μF	80 nF	640 nF	2,1 μF
Lo	4,2 mH	16,8 mH	32,6 mH	3,5 mH	14,2 mH	27,6 mH	2,9 mH	11,8 mH	22,8 mH
Lo/Ro	54 μH/Ω	218 μH/Ω	436 μH/Ω	50 μH/Ω	201 μH/Ω	402 μH/Ω	46 μH/Ω	184 μH/Ω	369 μH/Ω

Uo	9203B2A								
	Klemme 41-42			Klemme 41-43			Klemme 41-44		
	28 V			28 V			28 V		
Io	115 mA			125 mA			135 mA		
Po	0,81 W			0,88 W			0,95 W		
Vudgang ubelastet	Min. 24 V			Min. 24 V			Min. 24 V		
Vudgang belastet	Min. 11,5 V		Min. 9 V	Min. 12,5 V		Min. 10 V	Min. 13,5 V		Min. 11 V
Iudg. max	50 mA		60 mA	50 mA		60 mA	50 mA		60 mA
	IIC	IIB	IIA	IIC	IIB	IIA	IIC	IIB	IIA
Co	80 nF	640 nF	2,1 µF		640 nF	2,1 µF		640 nF	2,1 µF
Lo	2,69 mH	10,8 mH	20,8 mH		9,1 mH	17,6 mH		7,8 mH	15,1 mH
Lo/Ro	44 µH/Ω	176 µH/Ω	353 µH/Ω		163 µH/Ω	327 µH/Ω		150 µH/Ω	301 µH/Ω

### Relæudgang:

Statusrelæ i sikkert område:

Max. spænding ..... 125 VAC / 110 VDC  
 Max. strøm ..... 0,5 A AC / 0,3 A DC  
 Max. effekt ..... 62,5 VA / 32 W

**Godkendelser:**

EMC 2004/108/EF .....	EN 61326-1
LVD 2006/95/EF .....	EN 61010-1
UL, Standard for Safety .....	UL 61010-1
GOST R	

**Marine:**

Det Norske Veritas, Ships & Offshore ..... Stand. f. Certific. No. 2.4

**I.S. / Ex:**

ATEX 94/9/EF .....	KEMA 07ATEX0147 X
IECEX.....	IECEX KEM 09.0001X
c FM us .....	3035277-C
GOST Ex	

**Funktionel sikkerhed:**

SIL 2-certificeret via Full Assessment iht. IEC 61508

## Hardware- / softwarefejl

Visning ved hardwarefejl		
Fejlsøgning	Visning	Årsag
Test af kommunikation mellem 4501 / 9203	NO.CO	Fejl i stikforbindelse
EEProm-fejl - check konfiguration	FL.ER	Konfigurationsfejl eller crc-mismatch, recovery-konfiguration er indlæst
Hardwarefejl	DE.ER	Ugyldig recovery-konfiguration i modulet
Hardwarefejl	FC.ER	Ugyldig kode-checksum i 4501
EEProm-fejl - check konfiguration	CO.ER	Ugyldig konfiguration (CRC eller data)
Hardwarefejl	CA.ER	Fejl i fabrikskalibrering
Hardwarefejl	HW.ER	HW-setup - konfigurations-mismatch
Hardwarefejl	OC.ER	Kommunikationsfejl i primær processorkontrol
Hardwarefejl	MS.ER	Primær intern forsyning uden for grænser
Hardwarefejl	MI.ER	Fejl i primær initialiserings-selvtest
Hardwarefejl	MC.ER	Fejl i primær flash eller ram selvtest

! Alle fejlvisninger i display blinker 1 gang pr. sekund samt suppleres med tilhørende hjælpetekst.

Fejl, som har indflydelse på begge kanaler, vises som kanal 1 fejl - og kanal 2's linie er blank.

Hardwarefejl kan resettes på to måder. Man kan steppe gennem menuerne, f.eks. hvis den anden kanal skal køre videre, eller slukke og tænde for modulet.

# TILSLUTNINGER

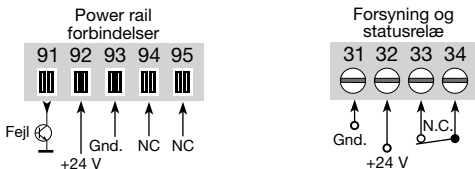

NC = Ingen forbindelse

## Indgang:

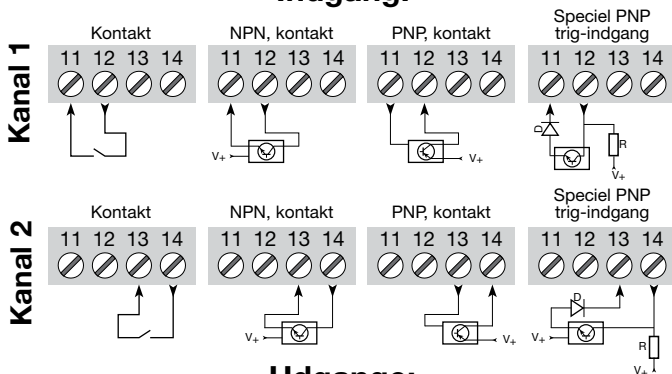

## Udgange:

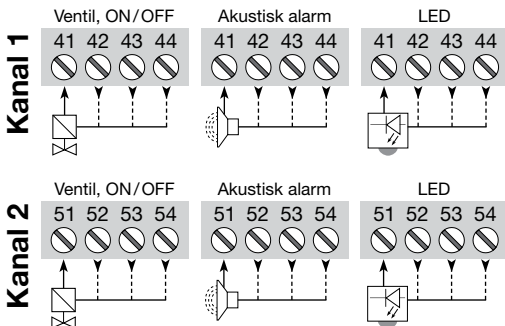



# BLOKDIAGRAM

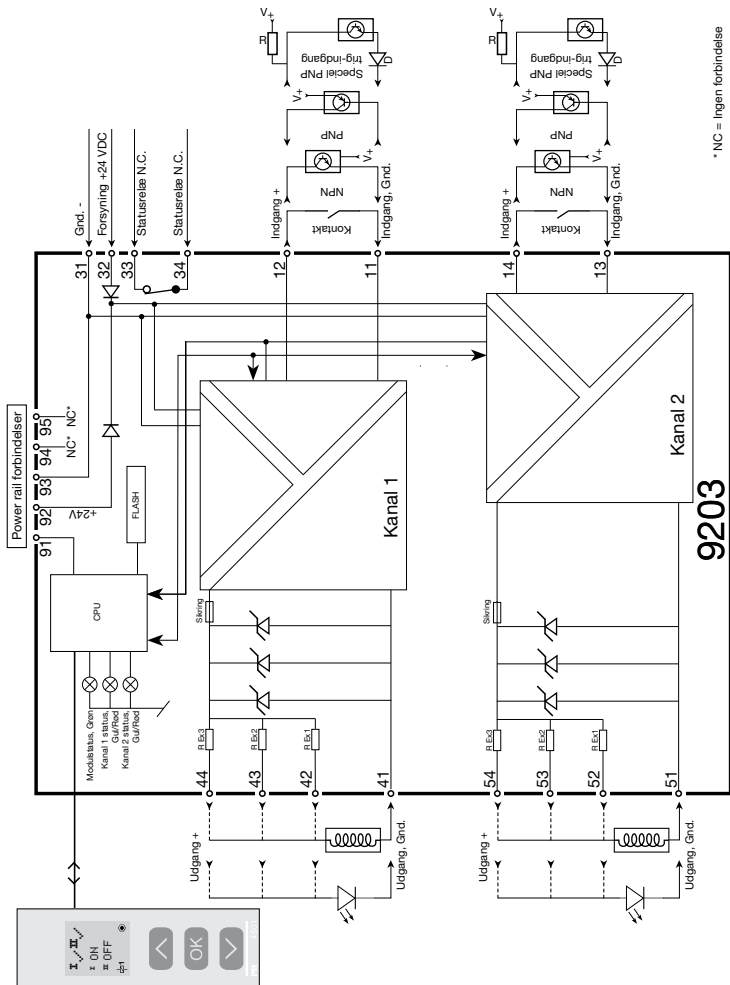

\* NC = Ingen forbindelse

## Visning af signalfejl uden displayfront

Liste over LED- og fejlsignalvisninger					
Status	Grøn LED	Kanal 1: Gul / Rød	Kanal 2: Gul / Rød	Statusrelæ, N.C.	Power rail signalstatus
Modul OK	Blinker			Trukket	OFF
Ingen forsyning	OFF	OFF	OFF	Sluppet	ON
Modul defekt	OFF	Rød	Rød	Sluppet	ON
Kanal 1, udgang ON	Blinker	Gul		Trukket	OFF
Kanal 1, udgang OFF	Blinker	OFF		Trukket	OFF
Kanal 2, udgang ON	Blinker		Gul	Trukket	OFF
Kanal 2, udgang OFF	Blinker		OFF	Trukket	OFF

## PROGRAMMERING / BETJENING AF TRYKKNAPPER

Dokumentation til rutediagram

### Generelt

Når du skal konfigurere 9203, bliver du guidet igennem samtlige parametre og kan vælge netop de indstillinger, der passer til applikationen. Til hver menu findes en rullende hjælpetekst, som vises i displaylinie 3.

Konfigurationen udføres ved hjælp af de 3 taster:

- ⤴ forøger talværdien eller vælger næste parameter
- ⤵ formindsker talværdien eller vælger forrige parameter
- Ⓚ accepterer valget og går til næste menu

Når konfigurationen er gennemført, returneres til normaltilstand 1.0.

Tryk og hold Ⓚ tasten nede for at gå til forrige menu eller normaltilstand (1.0) uden at gemme de ændrede tal eller parametre.

Hvis ingen taster har været aktiveret i 1 minut, returnerer displayet til normaltilstand (1.0) uden at gemme de ændrede tal eller parametre.

## Uddybende forklaringer

**Passwordbeskyttelse:** Programmeringsadgang kan forhindres ved indkodning af et password. Passwordet gemmes i modulet, så sikkerheden mod uønskede ændringer er så høj som muligt. Default password 2008 giver adgang til alle programmeringsmenuer.

## Signal- og modulfejlsinformation via displayfront 4501

Displayfronten 4501 kan konfigureres til at vise udgangsstatus, udgangsstrøm eller TAG.-nr. for begge kanaler. Ved hardwarefejl vises en forklarende hjælpetekst i displayet.

## Avancerede funktioner

Enheden giver adgang til en række avancerede funktioner, der nås ved at svare "yes" til punktet "adv.set".

**Display setup:** Her kan man justere kontrast og baggrundsbelysning. Opsætning af TAG-nummer med 5 alfanumeriske karakterer. Valg af funktionsvisning i linie 2 og 3 på displayet; der vælges mellem visning af udgangsstatus, udgangsstrøm og TAG-nr. Vælges "ALT" skifter displayet mellem de forskellige visningsmuligheder.

**Password:** Her kan vælges et password mellem 0000 og 9999 til beskyttelse mod uautoriserede ændringer. Enheden leveres default uden password.

**Sprog:** Der kan i menuen "LANG" vælges mellem 7 forskellige sprogvarianter af hjælpetekster, der fremkommer i menuen. Der kan vælges mellem UK, DE, FR, IT, ES, SE og DK.

**Safety Integrity Level (SIL):** Se Safety Manual (engelsk) for yderligere information.



# RUTEDIAGRAM

Hvis ingen taster har været aktiveret i 1 minut, returnerer displayet til normaltilstanden 1.0 uden at gemme eventuelle konfigurationsændringer.

- ⤴ Forøgelse af værdi / vælg næste parameter
  - ⤵ Formindskelse af værdi / vælg forrige parameter
  - ⊞ Accepter valget og gå til næste menu
- Holdt ⊞ går til forrige menu / returnerer til 1.0 uden at gemme

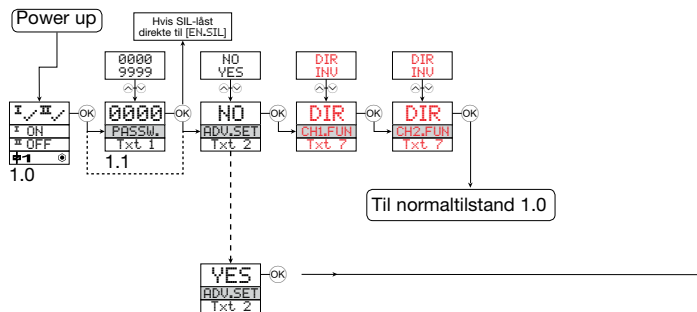

1.0 = Normaltilstand

Linie 1 viser status for kanal 1 og kanal 2.

Linie 2 viser udgangsstatus, udgangsstrøm eller TAG.-nr. for kanal 1.

Linie 3 viser udgangsstatus, udgangsstrøm eller TAG.-nr. for kanal 2.

Linie 4 indikerer om modulet er SIL-låst.

1.1 = Kun hvis beskyttet med password

1.2 = Kun hvis password er valgt.

Linie 1 symboler:

ⓘ = OK. Blinkende ⓘ = fejl.

Linie 2 og 3 symboler:

ⓘ ON = kanal 1 ON

ⓘ OFF = kanal 2 OFF.

Linie 4 symboler:

Statisk prik = SIL-låst.

Blinkende prik = ikke SIL-låst.

⊞ = udgangen er aktiv.

**Rød tekst** viser safety parametre i en SIL-konfiguration. Se Safety Manual for yderligere information.

## RUTEDIAGRAM, Avancerede indstillinger (ADV.SET)

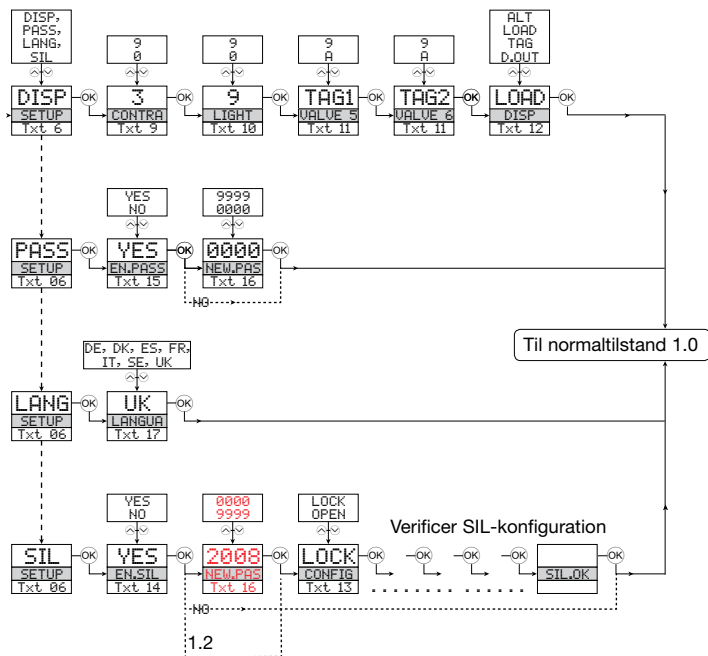

## RULLENDE HJÆLPETEKSTER I DISPLAYLINIE 3

- [01] Angiv korrekt password
- [02] Gå til avanceret opsætningsmenu?
- [06] Gå til valg af sprog
  - Gå til password-indstilling
  - Gå til displayopsætning
  - Gå til valg af SIL-låsning
- [07] Vælg direkte signalbehandling
  - Vælg inverteret signalbehandling
- [09] Juster LCD-kontrast
- [10] Juster LCD-baggrundsbelysning
- [11] Angiv et 5-karakters TAG-nr.
- [12] Udgangsbetoning vises i display
  - TAG-nr. vises i display
  - Skiftende værdier vises i display
- [13] Konfigurationens SIL-status (åben / låst)
- [14] Vælg at SIL-låse konfigurationen
- [15] Aktiver passwordbeskyttelse?
- [16] Angiv nyt password
- [17] Vælg sprog
- [20] Ingen kommunikation - kontroller stikforbindelser
- [21] Fejl i EEprom - kontroller konfiguration
- [22] Hardware-fejl

# **APPENDIX**

**IECEX INSTALLATION DRAWING**

**ATEX INSTALLATION DRAWING**

**FM INSTALLATION DRAWING**

**SAFETY MANUAL**

## IECEX Installation drawing



For safe installation of 9203B the following must be observed. The module shall only be installed by qualified personnel who are familiar with the national and international laws, directives and standards that apply to this area.

Year of manufacture can be taken from the first two digits in the serial number.



For installation in Zone 2 / Division 2 the following must be observed. The 4501 programming module is to be used solely with PRelectronics modules. It is important that the module is undamaged and has not been altered or modified in any way. Only 4501 modules free of dust and moisture shall be installed.

**IECEX Certificate:** IECEx KEM 09.0001X

**Marking**  
 [Ex ia Ga] IIC/IIB/IIA  
 Ex nA nC IIC T4 Gc  
 [Ex ia Da] IIIC  
 [Ex ia Ma] I

**Standards** IEC60079-15:2005, IEC60079-11:2011, IEC60079-0:2011  
 IEC60079-26:2006

### Installation notes.

Install in pollution degree 2, overvoltage category II as defined in IEC60664-1

Do not separate connectors when energized and an explosive gas mixture is present.

Do not mount or remove modules from the Power Rail when an explosive gas mixture is present.

Disconnect power before servicing.

The wiring of unused terminals is not allowed.

In type of protection [Ex ia Da] the parameters for intrinsic safety for gas group IIB are applicable.

For installation in Zone 2, the module shall be installed in an enclosure in type of protection Ex n or Ex e, providing a degree of protection of at least IP54. Cable entry devices and blanking elements shall fulfill the same requirements.

For installation on Power Rail in Zone 2, only Power Rail type 9400 supplied by Power Control Unit type 9410 (Type Examination Certificate KEMA 07ATEX0152 X) is allowed.



Hazardous area  
Zone 0, 1, 2, 20, 21, 22

Non Hazardous area  
or Zone 2

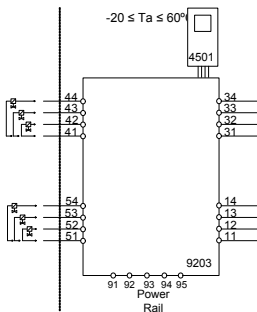

**Supply / Input**  
**(terminal 11,12,13,14)**  
**(terminal 31,32,33,34)**  
**(terminal 91,92,93,94,95)**  
 $U_m$ : 253V, max. 400Hz

**Terminal (31,32)**

**Supply:**

Voltage 19.2 – 31.2 VDC  
Power max. 3.5 W

**Terminal (11,12 and 13,14)**

**Input:**

Voltage max 28VDC  
Trig: NPN Low < 2 V, High > 4 V  
Trig: PNP Low < 8 V, High > 10 V

**Terminal (33,34)**

**Status Relay:**

**Non Hazardous location**  
Voltage max. 125 VAC / 110 VDC  
Power max. 62.5 VA / 32 W  
Current max. 0.5 AAC / 0.3 ADC

**Zone 2 installation**

32 VAC / 32 VDC  
16 VA / 32 W  
0.5 AAC / 1 ADC

9203B1A, 9203B1B Terminal 41-42/51-52						9203B2A Terminal 41-42					
U <sub>o</sub>	28V	IIC	Co	Lo	Lo/Ro	U <sub>o</sub>	28V	IIC	Co	Lo	Lo/Ro
			80nF	4.2mH	54μH/Ω				80nF	2.69mH	44μH/Ω
I <sub>o</sub>	93 mA	IIB	640nF	16.8mH	218μH/Ω	I <sub>o</sub>	115mA	IIB	640nF	10.8mH	176μH/Ω
P <sub>o</sub>	0.65W	IIA	2.1μF	32.6mH	436μH/Ω	P <sub>o</sub>	0.81W	IIA	2.1μF	20.8mH	353μH/Ω
		I	3.76μF	32.6mH	436μH/Ω			I	3.76μF	20.8mH	353μH/Ω
9203B1A, 9203B1B Terminal 41-43/51-53						9203B2A Terminal 41-43					
U <sub>o</sub>	28V	IIC	Co	Lo	Lo/Ro	U <sub>o</sub>	28V	IIC	Co	Lo	Lo/Ro
			80nF	3.5mH	54μH/Ω						
I <sub>o</sub>	100mA	IIB	640nF	14.2mH	218μH/Ω	I <sub>o</sub>	125mA	IIB	640nF	9.1mH	163μH/Ω
P <sub>o</sub>	0.70W	IIA	2.1μF	27.6mH	436μH/Ω	P <sub>o</sub>	0.88W	IIA	2.1μF	17.6mH	327μH/Ω
		I	3.76μF	27.6mH	436μH/Ω			I	3.76μF	17.6mH	327μH/Ω
9203B1A, 9203B1B Terminal 41-44/51-54						9203B2A Terminal 41-44					
U <sub>o</sub>	28V	IIC	Co	Lo	Lo/Ro	U <sub>o</sub>	28V	IIC	Co	Lo	Lo/Ro
			80nF	2.9mH	46μH/Ω						
I <sub>o</sub>	110mA	IIB	640nF	11.8mH	184μH/Ω	I <sub>o</sub>	135mA	IIB	640nF	7.8mH	150μH/Ω
P <sub>o</sub>	0.77W	IIA	2.1μF	22.8mH	369μH/Ω	P <sub>o</sub>	0.95W	IIA	2.1μF	15.1mH	301μH/Ω
		I	3.76μF	22.8mH	369μH/Ω			I	3.76μF	15.1mH	301μH/Ω

## ATEX Installationstegning



For sikker installation af 9203B skal følgende overholdes: Modulet må kun installeres af kvalificerede personer, som er bekendt med national og international lovgivning, direktiver og standarder i det land, hvor modulet skal installeres.  
Produktionsår fremgår af de to første cifre i serienummeret



For installation i zone 2 / division 2 skal følgende overholdes:  
Den aftagelige displayfront til programmering 4501 er udelukkende beregnet til brug på PR electronics moduler. Det er vigtigt, at displayet er ubeskadiget, ikke ombygget eller på anden måde forandret. 4501 må kun anvendes, hvis det er fri for støv og/eller fugt.

ATEX-certifikat KEMA 07ATEX 0147 X

### Mærkning



II (1) G [Ex ia Ga] IIC/IIB/IIA  
II 3G Ex nA nC IIC T4 Gc  
I (1) D [Ex ia Da] IIIC  
I (M1) [Ex ia Ma] I

### Standarder

EN 60079-0 : 2009, EN 60079-11 : 2007, EN 60079-15 : 2005  
EN 60079-26 : 2007, EN 61241-11 : 2006

### Klemme (31,32)

Forsyning:  
Spænding 19,2 – 31,2 VDC  
Max. forbrug 3,5 W

### Klemme (11,12 og 13,14)

Indgang:  
Spænding Max. 28 VDC  
Trig: NPN Low < 2 V, High > 4 V  
Trig: PNP Low < 8 V, High > 10 V

### Klemme (33,34)

Statusrelæ:	Ikke-eksplosionsfarligt område	Zone 2-installation
Max. spænding	125 VAC / 110 VDC	32 VAC / 32 VDC
Max. forbrug	62,5 VA / 32 W	16 VA / 32 W
Max. strøm	0,5 AAC / 0,3 ADC	0,5 AAC / 1 ADC

### Installationsforskrifter

Installer i forureningsgrad 2, overspændingskategori II som defineret i EN 60664-1.

Monter/demonter ikke stik, når forsyning er tilsluttet og der forefindes en eksplosionsfarlig gasblanding.

Monter/demonter ikke modulet på Power Rail, når der forefindes en eksplosionsfarlig gasblanding.

Afbryd forsyning før udførelse af vedligehold og reparation.

Fortrådning i ubenyttede terminaler er ikke tilladt.

Ved beskyttelsesmetode [Ex ia Da] er parametrene for egensikkerhed for gasgruppe IIB gældende.

For installation i zone 2 skal modulet installeres i et hus, som har beskyttelsestype Ex n eller Ex e, og som giver en IP-beskyttelse på mindst IP54. Kabelforskrutninger og blindstik skal opfyde samme krav.

Ved installation på Power Rail type 9400 i zone 2 er det kun tilladt at forsyne Power Rail ved brug af 9410 Power Control Unit (Type Examination Certificate KEMA 07ATEX0152 X).

Ex-område  
Zone 0,1,2, 20, 21, 22

Ikke Ex-område  
eller Zone 2

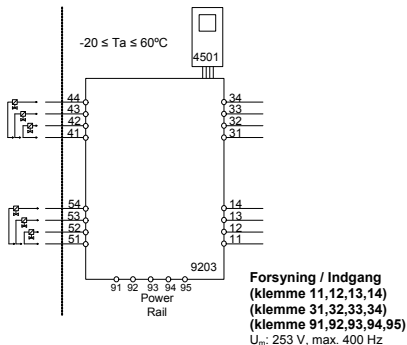

9203B1A, 9203B1B Klemme 41-42/51-52			Co	Lo	Lo/Ro	9203B2A Klemme 41-42			Co	Lo	Lo/Ro
Uo	28V	IIC	80nF	4,2mH	54μH/Ω	Uo	28V	IIC	80nF	2,69mH	44μH/Ω
Io	93 mA	IIB	640nF	16,8mH	218μH/Ω	Io	115mA	IIB	640nF	10,8mH	176μH/Ω
Po	0,65W	IIA	2,1μF	32,6mH	436μH/Ω	Po	0,81W	IIA	2,1μF	20,8mH	353μH/Ω
		I	3,76μF	32,6mH	436μH/Ω			I	3,76μF	20,8mH	353μH/Ω
9203B1A, 9203B1B Klemme 41-43/51-53			Co	Lo	Lo/Ro	9203B2A Klemme 41-43			Co	Lo	Lo/Ro
Uo	28V	IIC	80nF	3,5mH	54μH/Ω	Uo	28V	IIC			
Io	100mA	IIB	640nF	14,2mH	218μH/Ω	Io	125mA	IIB	640nF	9,1mH	163μH/Ω
Po	0,70W	IIA	2,1μF	27,6mH	436μH/Ω	Po	0,88W	IIA	2,1μF	17,6mH	327μH/Ω
		I	3,76μF	27,6mH	436μH/Ω			I	3,76μF	17,6mH	327μH/Ω
9203B1A, 9203B1B Klemme 41-44/51-54			Co	Lo	Lo/Ro	9203B2A Klemme 41-44			Co	Lo	Lo/Ro
Uo	28V	IIC	80nF	2,9mH	46μH/Ω	Uo	28V	IIC			
Io	110mA	IIB	640nF	11,8mH	184μH/Ω	Io	135mA	IIB	640nF	7,8mH	150μH/Ω
Po	0,77W	IIA	2,1μF	22,8mH	369μH/Ω	Po	0,95W	IIA	2,1μF	15,1mH	301μH/Ω
		I	3,76μF	22,8mH	369μH/Ω			I	3,76μF	15,1mH	301μH/Ω

## FM Installation drawing



For safe installation of 9203B the following must be observed. The module shall only be installed by qualified personnel who are familiar with the national and international laws, directives and standards that apply to this area.  
Year of manufacture can be taken from the first two digits in the serial number.



For Installation in Zone 2 / Division 2 the following must be observed.  
The 4501 programming module is to be used solely with PRElectronics modules. It is important that the module is undamaged and has not been altered or modified in any way. Only 4501 modules free of dust and moisture shall be installed.

c-FM-us Certificate

3035277

### Hazardous area

Class I/II/III, Division 1, Group A,B,C,D,E,F,G  
or Class I, Zone 0/1 Group IIC, [AEx ia] IIC or  
or Class I, Zone 0/1 Group IIC, [Ex ia] IIC

### Non Hazardous Area or

Class I, Division 2, Group A,B,C,D T4  
or Class I, Zone 2 Group IIC T4

Simple Apparatus or  
Intrinsically safe apparatus  
with entity parameters:  
 $V_{max}(U_i) \geq V_t(U_o)$   
 $I_{max}(I_i) \geq I_t(I_o)$   
 $P_i \geq P_t(P_o)$   
 $Ca(C_o) \geq C_{cable} + C_i$   
 $La(L_o) \geq L_{cable} + L_i$

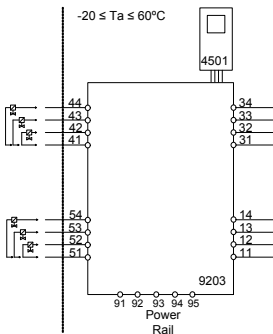

### Supply / Input

(terminal 11,12,13,14)  
(terminal 31,32,33,34)  
(terminal 91,92,93,94,95)  
 $U_{in}$ : 253V, max. 400Hz

LERBAKKEN 10, 8410 RØNDE DENMARK

Module 9203B1A & 9203B1B Terminal 41-42 / 51-52			Co/Ca	Lo/La	Lo/Ro or La/Ra
Uo/Voc	28 V	IIC or A.B	80 nF	4.2 mH	54 µH/Ω
Io/Isc	93 mA	IIB or C.E.F	640 nF	16.8 mH	218 µH/Ω
Po	0.65 W	IIA or D.G	2.1 µF	32.6 mH	436 µH/Ω

Module 9203B2A Terminal 41-42			Co/Ca	Lo/La	Lo/Ro or La/Ra
Uo/Voc	28 V	IIC or A.B	80 nF	2.69 mH	44 µH/Ω
Io/Isc	115 mA	IIB or C.E.F	640 nF	10.8 mH	176 µH/Ω
Po	0.81 W	IIA or D.G	2.1 µF	20.8 mH	353 µH/Ω

Module 9203B1A & 9203B1B Terminal 41-43 / 51-53			Co/Ca	Lo/La	Lo/Ro or La/Ra
Uo/Voc	28 V	IIC or A.B	80 nF	3.5 mH	50 µH/Ω
Io/Isc	100 mA	IIB or C.E.F	640 nF	14.2 mH	201 µH/Ω
Po	0.70 W	IIA or D.G	2.1 µF	27.6 mH	402 µH/Ω

Module 9203B2A Terminal 41-43			Co/Ca	Lo/La	Lo/Ro or La/Ra
Uo/Voc	28 V	IIC or A.B	640 nF	9.1 mH	163 µH/Ω
Io/Isc	125 mA	IIB or C.E.F	640 nF	17.6 mH	327 µH/Ω
Po	0.88 W	IIA or D.G	2.1 µF	17.6 mH	327 µH/Ω

Module 9203B1A & 9203B1B Terminal 41-44 / 51-54			Co/Ca	Lo/La	Lo/Ro or La/Ra
Uo/Voc	28 V	IIC or A.B	80 nF	2.9 mH	46 µH/Ω
Io/Isc	110 mA	IIB or C.E.F	640 nF	11.8 mH	184 µH/Ω
Po	0.77 W	IIA or D.G	2.1 µF	22.8 mH	369 µH/Ω

Module 9203B2A Terminal 41-44			Co/Ca	Lo/La	Lo/Ro or La/Ra
Uo/Voc	28 V	IIC or A.B	640 nF	7.8 mH	150 µH/Ω
Io/Isc	135 mA	IIB or C.E.F	640 nF	15.1 mH	301 µH/Ω
Po	0.95 W	IIA or D.G	2.1 µF	15.1 mH	301 µH/Ω

**Terminal (31,32)**
**Supply:**

Voltage	19.2 – 31.2 VDC
Power max.	3.5 W

**Terminal (11,12 and 13,14)**
**Input:**

Voltage	max 28VDC
Trig: NPN	Low < 2V, High > 4V
Trig: PNP	Low < 8V, High > 10V

**Terminal (33,34)**
**Status Relay:**

Voltage max.	125 VAC / 110 VDC
Power max.	62.5 VA / 32 W
Current max.	0.5 AAC / 0.3 ADC

**Non Hazardous location:**
**Division 2 or Zone 2 installation:**

Voltage max.	32 VAC / 32VDC
Power max.	16 VA / 32 W
Current max.	0.5 AAC / 1 ADC

**Installation notes:**

The installation and wiring shall be in accordance with the Canadian Electrical Code for Canada and National Electrical Code NFPA 70, Article 500 or 505 for installation in USA.

The module must be supplied from a Power Supply having double or reinforced insulation.

The use of stranded wires is not permitted for mains wiring except when wires are fitted with cable ends.

For installation on the 9400 Power Rail the power must be supplied from Power Control Module Unit 9410.

Install in pollution degree 2, overvoltage category II.

The module must be installed in an enclosure suitable for the environment for which it is used.

For installation in Zone 2 or Division 2, the module must be installed in a suitable outer enclosure according to the regulations in the CEC for Canada or NEC for USA.

The module is galvanically isolated and does not require grounding.

Use 60 / 75 °C copper conductors with wire size AWG: (26-14).

The maximum internal Power dissipation for adjacent modules is assumed to be max. 2W each.

**Warning:** Substitution of components may impair intrinsic safety and / or suitability for Div. 2 / Zone 2.

**Warning:** To prevent ignition of explosive atmospheres, disconnect power before servicing and do not separate connectors when energized and an explosive gas mixture is present.

**Warning:** Do not mount or remove modules from the Power Rail when an explosive gas mixture is present.

Revision date:

2011-11-20

Version Revision

V5 R0

Prepared by:

PB

Page:

2/2

# **SAFETY MANUAL**

## **SOLENOID / ALARM DRIVER**

**9203**

**This safety manual is valid for the following product versions:**

**9203-001**

**9203-002**



## 0. CONTENTS

1. Observed standards .....	2
2. Acronyms and abbreviations .....	2
3. Purpose of the product .....	3
4. Assumptions and restrictions for use of the product.....	3
4.1 Basic safety specifications .....	3
4.2 Associated equipment.....	3
4.2.1 Safety output.....	3
4.2.2 Safety input.....	3
4.3 Failure rates .....	3
4.4 Safe parameterisation.....	4
4.5 Installation in hazardous areas .....	4
5. Functional specification of the safety functions.....	4
6. Functional specification of the non-safety functions .....	4
7. Safety parameters .....	4
8. Hardware and software configuration .....	5
9. Failure category.....	5
10. Periodic proof test procedure .....	5
11. Procedures to repair or replace the product.....	5
12. Maintenance.....	5
13. Documentation for routing diagram .....	6
13.1 In general .....	6
13.2 Further explanations .....	6
13.2.1 Password protection .....	6
13.4 Advanced functions.....	6
13.4.1 Display setup .....	7
13.4.2 Password .....	7
13.4.3 Language .....	7
13.4.4 Power rail .....	7
13.4.5 Safety integrity level.....	7
14 Safe parameterisation - user responsibility.....	8
14.1 Safety-related configuration parameters.....	8
14.2 Verification procedure.....	8
14.2.1 If no password is set.....	8
14.2.2 If password is set.....	9
14.3 Functional test.....	9
15. Fault reaction and restart condition .....	9
16 User interface .....	10
16.1 Scrolling help texts in display line 3.....	10
16.3 Routing diagram - Advanced settings (ADV.SET).....	12
17 Connections diagram .....	13

## 1. Observed standards

Standard	Description
IEC 61508	Functional Safety of electrical / electronic / programmable electronic safety-related systems
IEC 61508-2:2000	Part 2: Requirements for electrical / electronic / programmable electronic safety-related systems
IEC 61508-3:1998	Part 3: Software requirements
IEC 61326-3-1:2008	Immunity requirements for safety-related systems

## 2. Acronyms and abbreviations

Acronym / Abbreviation	Designation	Description
Element		Term defined by IEC 61508 as “part of a subsystem comprising a single component or any group of components that performs one or more element safety functions”
PFD	Probability of Failure on Demand	This is the likelihood of dangerous safety function failures occurring on demand.
PFH	Probability of dangerous Failure per Hour	The term “Probability” is misleading, as IEC 61508 defines a Rate.
SFF	Safe Failure Fraction	Safe Failure Fraction summarises the fraction of failures which lead to a safe state and the fraction of failures which will be detected by diagnostic measures and lead to a defined safety action.
SIF	Safety Integrity Function	Function that provides fault detection (to ensure the necessary safety integrity for the safety functions)
SIL	Safety Integrity Level	The international standard IEC 61508 specifies four discrete safety integrity levels (SIL 1 to SIL 4). Each level corresponds to a specific probability range regarding the failure of a safety function.

### 3. Purpose of the product

Universal Ex driver for the control of solenoids etc. with various Ex data by way of three built-in Ex barriers.

The device can be mounted in the safe area and in zone 2 / div. 2 and transmit signals to zone 0, 1, 2, 20, 21 and 22.

Ex driver for the control of ON / OFF solenoids, acoustic alarms and LEDs mounted in the hazardous area.

The 9203 is controlled by an NPN/PNP signal or a switch signal.

Monitoring of internal error events via the individual status relay and/or a collective electronic signal via the power rail.

The 9203 has been designed, developed and certified for use in SIL 2 applications according to the requirements of IEC 61508.

### 4. Assumptions and restrictions for use of the product

#### 4.1 Basic safety specifications

Operational temperature range .....	-20...+60°C
Storage temperature range .....	-20...+85°C
Power supply type, min.....	Double or reinforced
Supply voltage.....	19.2...31.2 VDC
Mounting area.....	Zone 2 / Division 2 or safe area
Mounting environment.....	Pollution degree 2 or better

#### 4.2 Associated equipment

##### 4.2.1 Safety output

The safety output shall be connected to the equipment with a minimum load of 10 K $\Omega$

##### 4.2.2 Safety input

The safety input signal frequency shall not be higher than 20 Hz, and the pulse length shall not be shorter than 25 ms.

#### 4.3 Failure rates

The basic failure rates from the Siemens standard SN 29500 are used as the failure rate database.

Failure rates are constant, wear-out mechanisms are not included.

External power supply failure rates are not included.

#### 4.4 Safe parameterisation

The user is responsible for verifying the correctness of the configuration parameters. (See section 14 Safe parameterisation - user responsibility). Manual override may not be used for safety applications.

#### 4.5 Installation in hazardous areas

The IECex Installation drawing, ATEX Installation drawing and FM Installation drawing shall be followed if the products are installed in hazardous areas.

### 5. Functional specification of the safety functions

Ex driver for the control of ON / OFF solenoids, acoustic alarms and LEDs mounted in the hazardous area.

### 6. Functional specification of the non-safety functions

The status relay (terminal 33 and 34), error signal on power rail (terminal 91) and LED outputs are not suitable for use in any Safety Instrumented Function.

### 7. Safety parameters

	B1A, B1B	B2A
Probability of dangerous Failure per Hour (PFH)	4.30E-08	4.60E-08
	Note <sup>1</sup>	
Probability of failure on demand (PFD) - 1 year proof test interval	2.73E-04	2.92E-04
Proof test interval (10% of loop PFD)	5 years	4 years
Safe Failure Fraction	91%	91%
Demand response time	<10 ms	
Demand mode	High	
Demand rate	1000 s	
Mean Time To Repair (MTTR)	24 hours	
Diagnostic test interval	10 seconds	
Hardware Fault Tolerance (HFT)	0	
Component Type	B	
SIL capability	SIL 2	
Description of the "Safe State"	De-energised	

Note<sup>1</sup>: The 9203 contains no lifetime limiting components, therefore the PFH figures are valid for up to 12 years, according to IEC 61508.

## 8. Hardware and software configuration

All configurations of software and hardware versions are fixed from factory, and cannot be changed by end-user or reseller.

This manual only covers products labelled with the product version (or range of versions) specified on the front page.

## 9. Failure category

Failure category	Failure rates (1/h)	
	B1A, B1B	B2A
Fail Safe Detected	0.00E+00	0.00E+00
Fail Safe Undetected	4.77E-07	4.80E-07
Fail Dangerous Detected	0.00E+00	0.00E+00
Fail Dangerous Undetected	4.30E-08	4.60E-08

## 10. Periodic proof test procedure

Step	Action
1	Bypass the safety PLC or take other appropriate action to avoid a false trip
2	Connect a simulator identical to the input setup
3	Perform an ON / OFF signal for each channel
4	Observe whether the output channel acts as expected
5	Restore the input terminals to full operation
6	Remove the bypass from the safety PLC or otherwise restore normal operation

This test will detect approximately 95% of possible “du” (dangerous undetected) failures in the device. The proof test is equivalent to the functional test.

## 11. Procedures to repair or replace the product

Any failures that are detected and that compromise functional safety should be reported to the sales department at PR electronics A/S.

Repair of the device and replacement of circuit breakers must be done by PR electronics A/S only.

## 12. Maintenance

No maintenance required.

## 13. Documentation for routing diagram

The routing diagram is shown in section 16.2.

### 13.1 In general

When configuring the 9203, you will be guided through all parameters and you can choose the settings which fit the application. For each menu there is a scrolling help text which is automatically shown in line 3 on the display.

Configuration is carried out by use of the 3 function keys:

- ⬆ will increase the numerical value or choose the next parameter
- ⬇ will decrease the numerical value or choose the previous parameter
- OK will accept the chosen value and proceed to the next menu

When configuration is completed, the display will return to the default state 1.0.

Pressing and holding OK will return to the previous menu or return to the default state (1.0) without saving the changed values or parameters.

If no key is activated for 1 minute, the display will return to the default state (1.0) without saving the changed values or parameters.

### 13.2 Further explanations

#### 13.2.1 Password protection

Access to the configuration can be blocked by assigning a password. The password is saved in the device in order to ensure a high degree of protection against unauthorised modifications to the configuration. Default password 2008 allows access to all configuration menus.

Password protection is mandatory in SIL applications.

### 13.4 Advanced functions

The unit gives access to a number of advanced functions which can be reached by answering “Yes” to the point “adv.set”.

**13.4.1 Display setup**

Here you can adjust the brightness contrast and the backlight. Setup of tag numbers with 5 alphanumerics. Selection of functional readout in line 2 and 3 of the display - choose between readout of digital output or tag no. When selecting "ALT" the readout toggles between digital output and tag no.

**13.4.2 Password**

Here you can choose a password between 0000 and 9999 in order to protect the device against unauthorised modifications to the configuration. The device is delivered default without password.

**13.4.3 Language**

In the menu "LANG" you can choose between 7 different language versions of help texts that will appear in the menu. You can choose between UK, DE, FR, IT, ES, SE and DK.

**13.4.4 Power rail**

In the menu "RAIL" you can choose if errors in the device are transmitted to the central surveillance in the PR 9410 power control unit.

**13.4.5 Safety integrity level**

See Safe parameterisation - user responsibility

## 14 Safe parameterisation - user responsibility

### 14.1 Safety-related configuration parameters

Parameters	Value	Description
CH1.FUN	DIR / INV	Direct / inverted channel function
CH2.FUN.	DIR / INV	Direct / inverted channel function
PASSW	0 - 9999	New password

The above safety-related configuration parameters are marked in red text in the routing diagrams and must be verified by the user in a SIL-configuration.

### 14.2 Verification procedure

The verification is done using the display / programming front PR 4501 by following the procedure described below.

#### 14.2.1 If no password is set

	Action	Display shows
1	Press OK	ADV.SET
2	Set (ADV.SET) to Yes and press OK	DISP SETUP
3	Step down to (SIL SETUP) and press OK	EN.SIL
4	Set (EN SIL) to YES and press OK	NEW.PASS
5	Set password to a number between 0 and 9999 and press OK (At this time the device starts operating in SIL mode with the entered configuration parameters!)	Verify⇒OPEN "briefly" ⇒LOCK*
6	Press OK to confirm verification of the OPEN-LOCK in the display	CH1.FUN
7	Verify Channel 1 function and press OK	CH2:FUN
8	Verify Channel 2 function and press OK	PASSW
9	Verify password and press OK	SIL.OK
10	Verify SIL and press OK	

\* Open is shown briefly in the display.



**14.2.2 If password is set**

	<b>Action</b>	<b>Display shows</b>
1	Press OK	PASSW
2	Enter password and press OK	ADV.SET
3	Set (ADV.SET) to Yes and press OK	DISP SETUP
4	Step down to (SIL SETUP) and press OK	EN.SIL
5	Set (EN SIL) to YES and press OK (At this time the device starts operating in SIL mode with the entered configuration parameters!)	Verify⇒OPEN "briefly" ⇒LOCK*
6	Press OK to confirm verification of the OPEN-LOCK in the display	CH1.FUN
7	Verify Channel 1 function and press OK	CH2:FUN
8	Verify Channel 2 function and press OK	PASSW
9	Verify password and press OK	SIL.OK
10	Verify SIL and press OK	

\* Open is shown briefly in the display

**14.3 Functional test**

The user is responsible for making a functional test after verification of safety parameters. The procedure for periodic proof test described in section 10 shall be used.

**15. Fault reaction and restart condition**

When the 9203 detects a fault the output will go to Safe State, in which the safety output will go to "de-energised".

For device faults there are 2 ways of bringing the device out of Safe State.

1. Power cycle the device.
2. Bring the device out of SIL mode (choose "NO" in the menu point "EN.SIL"), and set it back to SIL mode again (choose "YES" in the menu point "EN.SIL" and verify the configuration).

## 16 User interface

### 16.1 Scrolling help texts in display line 3

- [01] Set correct password
- [02] Enter advanced setup?
- [06] Enter language setup
- Enter password setup
- Enter display setup
- Enter SIL setup
- [07] Select direct channel function
- Select inverted channel function
- [09] Adjust LCD contrast
- [10] Adjust LCD backlight
- [11] Write a 5-character channel tag
- [12] Show output state in display
- Show output load in display
- Show tag in display
- Alternate information shown in display
- [13] Configuration SIL status (Open / Locked)
- [14] Enable SIL configuration lock
- [15] Enable password protection?
- [16] Set new password
- [17] Select language
- [20] No communication - check connections
- [21] EProm error - check configuration
- [22] Hardware error

## ROUTING DIAGRAM

If no key is activated for 1 minute, the display will return to the default state 1.0 without saving configuration changes.

- ⤴ Increase value / choose next parameter
- ⤵ Decrease value / choose previous parameter
- ⊗ Accept the chosen value and proceed to the next menu
- Hold ⊗ Back to previous menu / return to menu 1.0 without saving

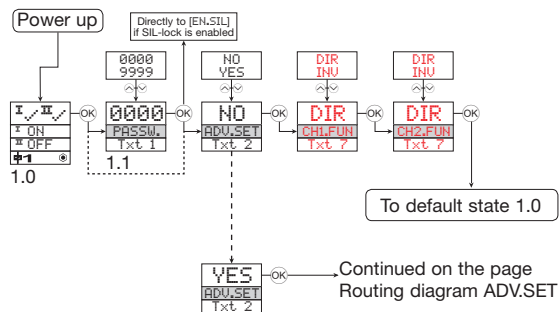

1.0 = Default state

Linie 1 shows status for channel 1 and channel 2.

Linie 2 shows output status for channel 1, output current or tag no.

Linie 3 shows output status for channel 2, output current or tag no.

Line 4 indicates whether the module is SIL-locked.

1.1 = Only if password-protected.

1.2 If password has been set.

Line 1 symbols:

I ✓ = OK. Flashing II = error.

Line 2 and 3 symbols:

I ON = channel 1 ON

II OFF = channel 2 OFF.

Line 4 symbols:

Static dot = SIL-locked.

Flashing dot = Not SIL-locked.

⊕ = output is active.

### 16.3 Routing diagram - Advanced settings (ADV.SET)

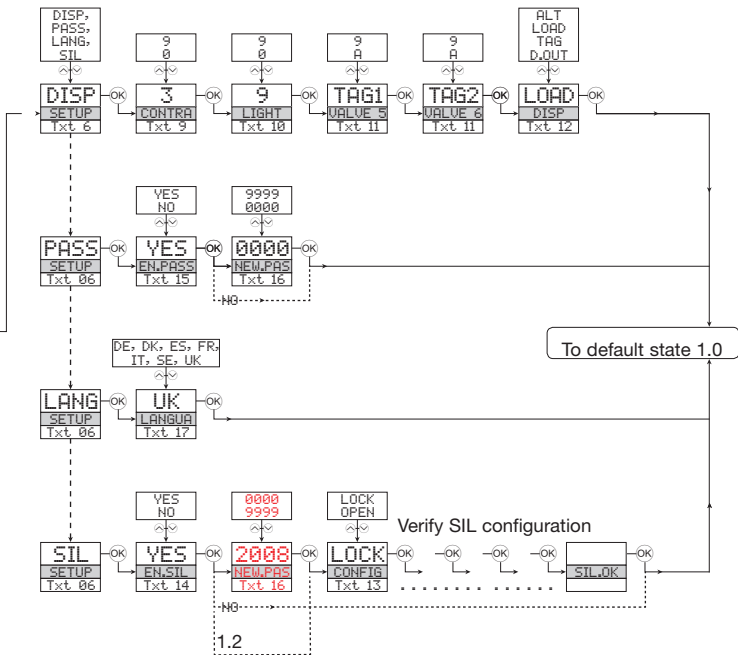

## 17 Connections diagram

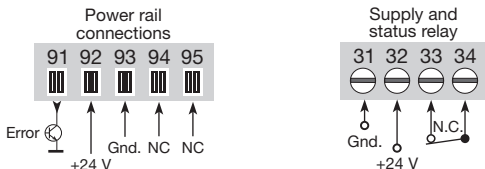

NC = No connection

### Inputs:

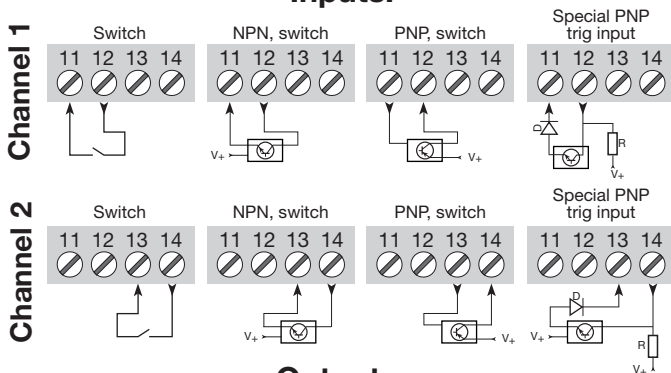

### Outputs:

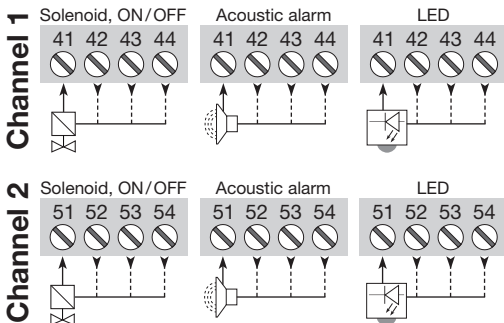



**Displays** Programmable displays with a wide selection of inputs and outputs for display of temperature, volume and weight, etc. Feature linearisation, scaling, and difference measurement functions for programming via PReset software.



**Ex interfaces** Interfaces for analogue and digital signals as well as HART® signals between sensors / I/P converters / frequency signals and control systems in Ex zone 0, 1 & 2 and for some modules in zone 20, 21 & 22.



**Isolation** Galvanic isolators for analogue and digital signals as well as HART® signals. A wide product range with both loop-powered and universal isolators featuring linearisation, inversion, and scaling of output signals.



**Temperature** A wide selection of transmitters for DIN form B mounting and DIN rail modules with analogue and digital bus communication ranging from application-specific to universal transmitters.



**Universal** PC or front programmable modules with universal options for input, output and supply. This range offers a number of advanced features such as process calibration, linearisation and auto-diagnosis.



- 
 [www.preelectronics.fr](http://www.preelectronics.fr)  
 [sales@preelectronics.fr](mailto:sales@preelectronics.fr)
- 
 [www.preelectronics.de](http://www.preelectronics.de)  
 [sales@preelectronics.de](mailto:sales@preelectronics.de)
- 
 [www.preelectronics.es](http://www.preelectronics.es)  
 [sales@preelectronics.es](mailto:sales@preelectronics.es)
- 
 [www.preelectronics.it](http://www.preelectronics.it)  
 [sales@preelectronics.it](mailto:sales@preelectronics.it)
- 
 [www.preelectronics.se](http://www.preelectronics.se)  
 [sales@preelectronics.se](mailto:sales@preelectronics.se)
- 
 [www.preelectronics.co.uk](http://www.preelectronics.co.uk)  
 [sales@preelectronics.co.uk](mailto:sales@preelectronics.co.uk)
- 
 [www.preelectronics.com](http://www.preelectronics.com)  
 [sales@preelectronics.com](mailto:sales@preelectronics.com)
- 
 [www.preelectronics.cn](http://www.preelectronics.cn)  
 [sales@preelectronics.cn](mailto:sales@preelectronics.cn)

## Head office

Denmark  
 PR electronics A/S  
 Lerbakken 10  
 DK-8410 Rønne

[www.preelectronics.com](http://www.preelectronics.com)  
[sales@preelectronics.dk](mailto:sales@preelectronics.dk)  
 tel. +45 86 37 26 77  
 fax +45 86 37 30 85



QUALITY SYSTEM AND ENVIRONMENTAL MANAGEMENT SYSTEM  
 DS/EN ISO 9001  
 DS/EN ISO 14001

